

M 1:1

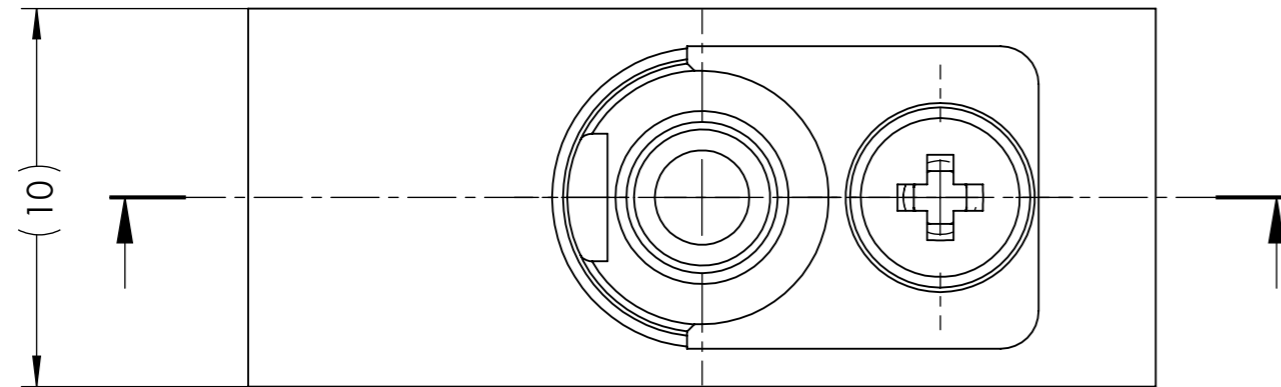
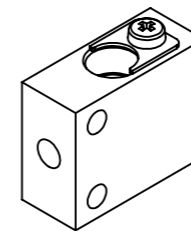

Zeichnung darf nur mit CAD geändert werden						Maßstab	5:1	SolidWorks - Zeichnung A3																						
						Werkstoff																								
<table border="1"> <thead> <tr> <th></th> <th></th> <th>Datum</th> <th>Name</th> </tr> </thead> <tbody> <tr> <td>Erstellt</td> <td>24.09.2002</td> <td>Märkle</td> <td></td> </tr> <tr> <td>Bearb.</td> <td>08.07.2016</td> <td>Mö</td> <td></td> </tr> <tr> <td>Gepr.</td> <td>13.07.2016</td> <td>RI</td> <td></td> </tr> <tr> <td>Norm.</td> <td>08.07.2016</td> <td>Mö</td> <td></td> </tr> </tbody> </table>						Datum	Name	Erstellt	24.09.2002	Märkle		Bearb.	08.07.2016	Mö		Gepr.	13.07.2016	RI		Norm.	08.07.2016	Mö				Benennung				
						Datum	Name																							
				Erstellt	24.09.2002	Märkle																								
				Bearb.	08.07.2016	Mö																								
Gepr.	13.07.2016	RI																												
Norm.	08.07.2016	Mö																												
<b>Montageplatte P07 kpl.</b>																														
					Artikel-Nr.	Index	Revision	Blatt																						
					567-000-090	A	002	1 / 2																						
<table border="1"> <thead> <tr> <th>a</th> <th></th> <th>03.07.07</th> <th>D.S</th> </tr> </thead> <tbody> <tr> <td>A.001</td> <td>2015-00067</td> <td>26.03.2015</td> <td>Ka</td> </tr> <tr> <td>A.002</td> <td>2016-00069</td> <td>14.07.2016</td> <td>Ka</td> </tr> <tr> <td>Index</td> <td>ToDo-Ä.-Nr.</td> <td>Datum</td> <td>Name</td> </tr> </tbody> </table>				a		03.07.07	D.S	A.001	2015-00067	26.03.2015	Ka	A.002	2016-00069	14.07.2016	Ka	Index	ToDo-Ä.-Nr.	Datum	Name	D-74391 Erligheim		Ersatz für								
a		03.07.07	D.S																											
A.001	2015-00067	26.03.2015	Ka																											
A.002	2016-00069	14.07.2016	Ka																											
Index	ToDo-Ä.-Nr.	Datum	Name																											

### Installation geometry suggestion

only needed if provided hold down clamp is used  
 (please contact our team for more information)

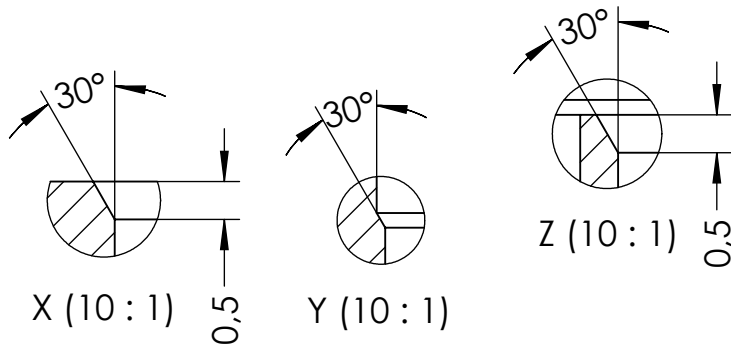
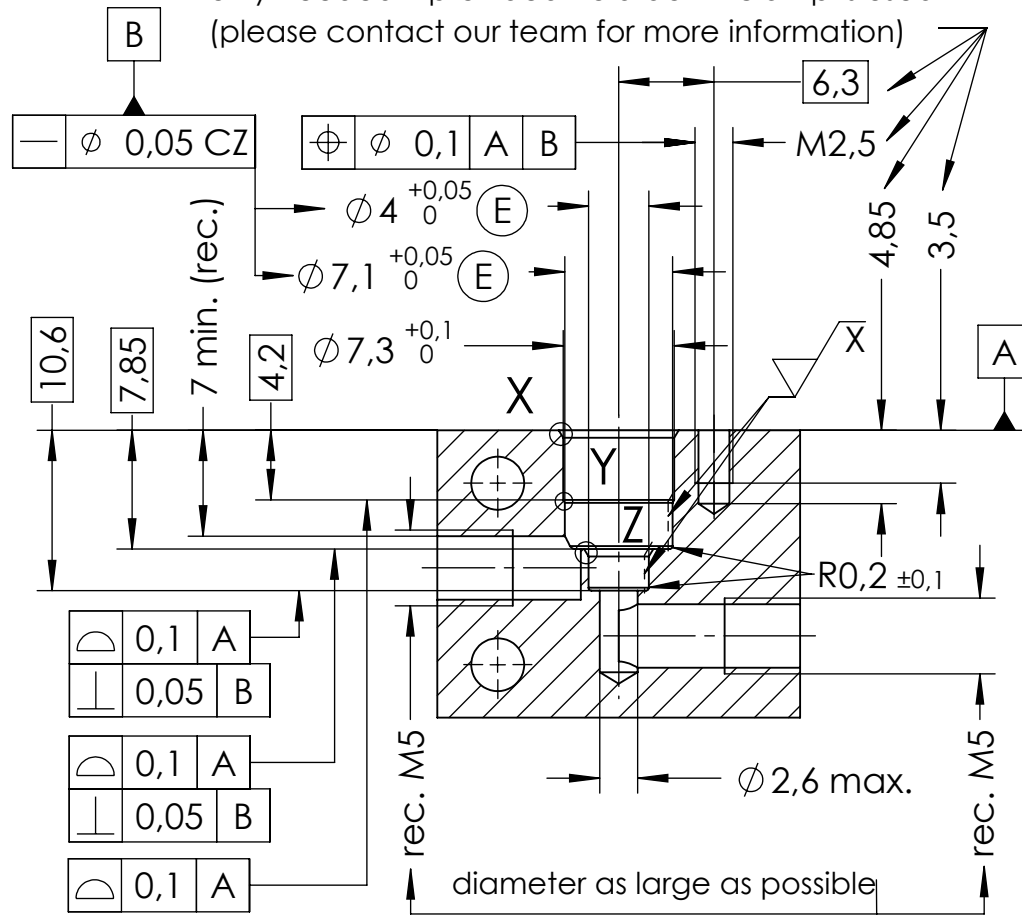

general tolerance acc. to DIN ISO 2768-mK  
 tolerances of form and position ISO 1101  
 tolerancing ISO 8015 : 2011

$$\sqrt{Ra\ 3,2} \left( \sqrt{X} = \sqrt{Rzmax.\ 6,3} \right)$$

Zeichnung darf nur mit CAD geändert werden						Maßstab 2:1	SolidWorks - Zeichnung A4				
						Werkstoff					
				Datum		Name					
				Erstellt 24.09.2002		Märkle					
				Bearb. 08.07.2016		Mö					
				Gepr. 13.07.2016		RI					
				Norm. 08.07.2016		Mö					
a		03.07.07		D.S		<b>Montageplatte P07 kpl.</b>					
A.001		2015-00067		26.03.2015						Ka	
A.002		2016-00069		14.07.2016						Ka	
Index		ToDo-Ä.-Nr.		Datum		Name					
						Artikel-Nr.		Index		Revision	Blatt
						567-000-090		A	002	2 / 2	
						Ersatz für					
						D-74391 Erligheim					